

OT600

BATTERY-POWERED ELECTRIC TUG
TO PULL LOADS **UP TO 2000 KG***

ZERO EMISSIONS

QUIET

LOW MAINTENANCE



Compact dimensions,
ideal for transport and
storage in narrow spaces



**Folding and height
adjustable tiller** for
better comfort of use



Butterfly accelerator,
easy to control with your
thumb



**Battery charger on
board,** display with light
indication of charge
status



The OT-600 is a towing equipment, with three wheels and tiller steering. It is designed to easily move trailer trolleys and other containers on wheels, in safety and comfort, reducing physical stress and improving productivity. Many configurations are possible by choosing among different types of batteries and tires. It can be fitted with several accessories that make the standard product adaptable to many uses.

ALITRAK[®]
ELECTRIC M I N D E D

www.alitrak.com

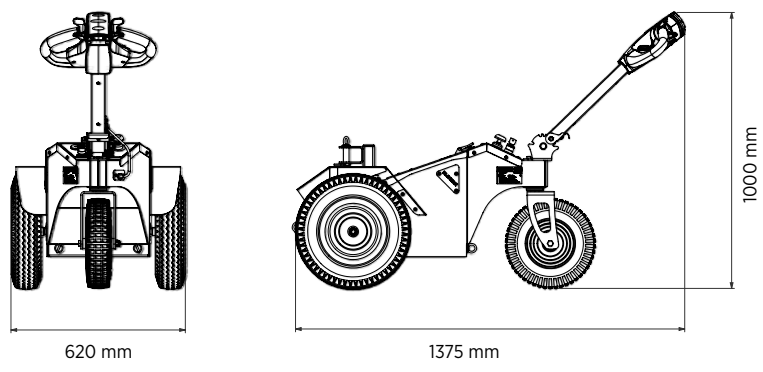

UNIforce DISTRIBUTION

UniForce Distribution Inc.
 Tel : (866) 889-1272
 Courriel : info@uniforcedistribution.com
 Web : www.uniforcedistribution.com

FEATURES

Equipment body	3 wheels
Driving wheels on differential	Trailer type
Driving control type	Foldable tiller
Accelerator	Butterfly type
Hook height	430 mm abt
Battery charger	On board, 13 A High Frequency
Dashboard display	Remaining battery charge
Parking brake	Electromagnetic with the possibility of release
Batteries	Flooded 2 x 12V/72 Ah C20 (or AGM 2 x 12V/85 Ah C20)
Electric motor	24V/600 watt S2 20 min
Product net weight	130 kg abt

PERFORMANCES



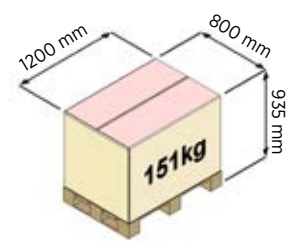

Weight movement capacity on flat surface up to*	2000 Kg
Pulling speed:	
Fast	5 Km/h abt
Slow	2,5 km/h abt
Pushing speed:	
Fast	3 Km/h abt
Slow	1,5 Km/h abt
Battery recharging time	8 hours abt



*The weight movement capacity is an indication., that can change with different machine fittings and working conditions (type of ground,wheel type,use of ballast,etc.)

Features shown are subject to change without notice

ACCESSORIES

- 
 Anti dumping wheel frame with additional hook heights
- 
 Direct steering system
- 
 Multifunctional wheel/tiller arm system
- 
 Clamp for trailer trolleys
- 
 Tug attachment for trash containers
- 
 Tow hitch ball
- 
 Ballast 9 Kg
- 
 Flashing light
- 
 Different tyres and tread profiles
- 
 Anti flat tire treatment by polyurethane filled wheels